

**Ventilconvettori**  
**Ventilo-convecteur**  
**Fan coil**  
**Klimatruhe**  
**Ventilatorconvetoren**  
**Convector ventilo**

COD.	MOD.	TYP.
20116254	Design Inverter 11B	
20116244	Design Inverter 21B	
20116246	Design Inverter 33B	
20116250	Design Inverter 40B	
20116252	Design Inverter 46B	
20116258	Design Inverter Plus 11B	
20116260	Design Inverter Plus 21B	
20116261	Design Inverter Plus 33B	
20116263	Design Inverter Plus 40B	
20116264	Design Inverter Plus 46B	
20116265	Design Inverter 6BS	
20116267	Design Inverter 11BS	
20116271	Design Inverter 17BS	
20116272	Design Inverter 23BS	
20116273	Design Inverter 32BS	
20116845	Design Inverter 11A	
20116924	Design Inverter 21A	
20116925	Design Inverter 33A	
20116928	Design Inverter 40A	
20116929	Design Inverter 46A	

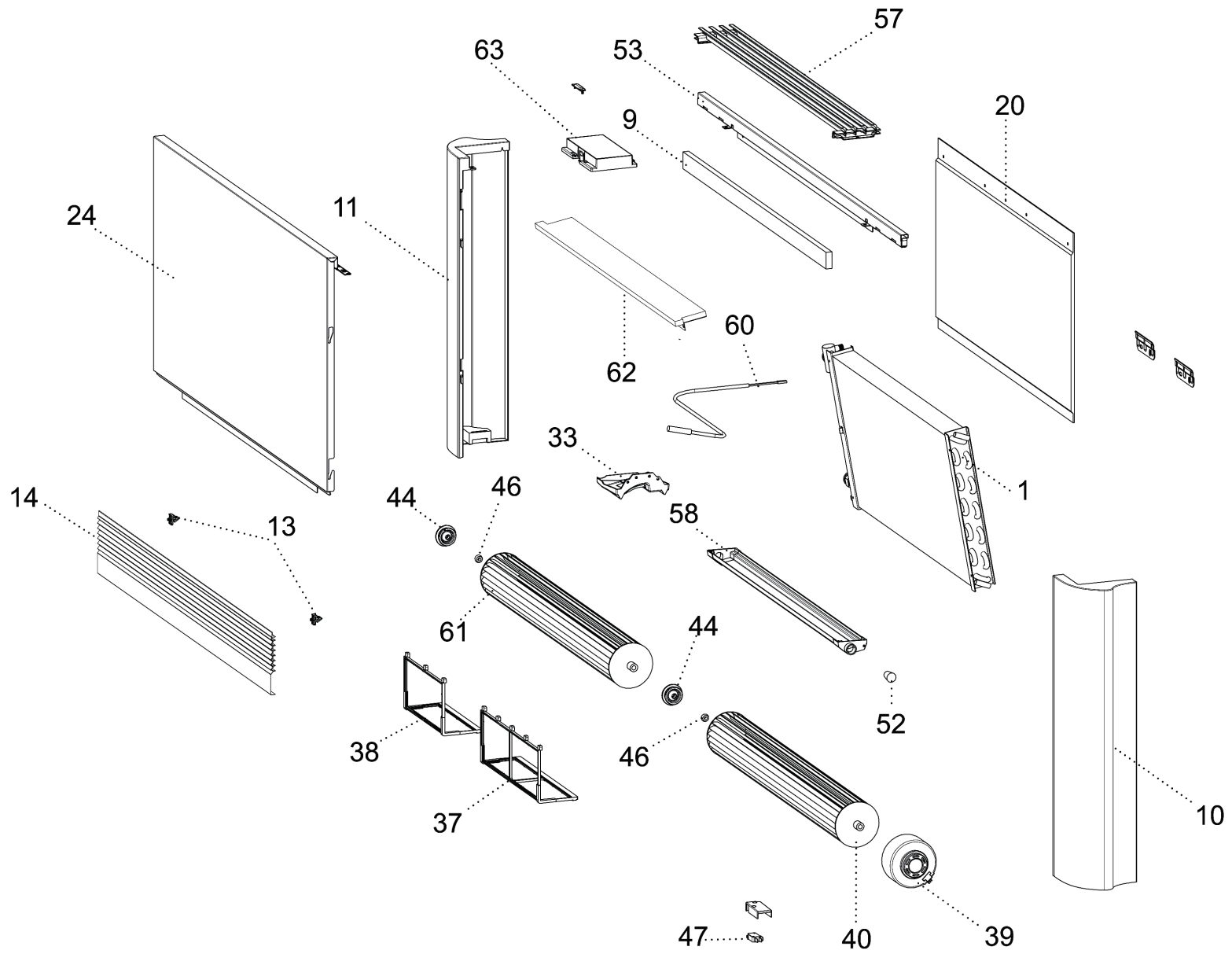

N.	COD.	RC	20116254	20116244	20116246	20116250	20116252	DESCRIZIONE	DESCRIPTION	DESCRIPTION	BESCHREIBUNG	BESCHRIJVING	DESCRIPCIÓN
1	4020813		•					Batteria	Batterie	Condenser	Batterie	Accu	Batería
1	4020826			•				Batteria	Batterie	Condenser	Batterie	Accu	Batería
1	4020832				•			Batteria	Batterie	Condenser	Batterie	Accu	Batería
1	4020838					•		Batteria	Batterie	Condenser	Batterie	Accu	Batería
1	4020844						•	Batteria	Batterie	Condenser	Batterie	Accu	Batería
9	4R000640		•					Isolante traversa superiore	Isolation	Protection	Isolierung	Isolatie	Aislante
9	4R000634			•				Isolante traversa superiore	Isolation	Protection	Isolierung	Isolatie	Aislante
9	4R000628				•			Isolante traversa superiore	Isolation	Protection	Isolierung	Isolatie	Aislante
9	4R000622					•		Isolante traversa superiore	Isolation	Protection	Isolierung	Isolatie	Aislante
9	4R000614						•	Isolante traversa superiore	Isolation	Protection	Isolierung	Isolatie	Aislante
10	4R104278		•	•	•	•	•	Fiancata destra	Habillage droit	Right side	Rechte Seitenwand	Rechter zijwand	Panel lateral derecho
11	4R104279		•	•	•	•	•	Fiancata sinistra	Habillage gauche	Left side	Linke Seitenwand	Linker zijwand	Panel lateral izquierdo
13	4R003010		•	•	•	•	•	Gancio griglia	Crochet	Hooks	Haken	Haak	Gancho
14	4R104280		•					Griglia	Grille	Guard	Gitter	Rooster	Rejilla
14	4R104285			•				Griglia	Grille	Guard	Gitter	Rooster	Rejilla
14	4R104289				•			Griglia	Grille	Guard	Gitter	Rooster	Rejilla
14	4R104293					•		Griglia	Grille	Guard	Gitter	Rooster	Rejilla
14	4R104297						•	Griglia	Grille	Guard	Gitter	Rooster	Rejilla
20	4R104281		•					Schienale	Châssis	Frame	Rückwand	Achterpaneel	Respaldo
20	4R104286			•				Schienale	Châssis	Frame	Rückwand	Achterpaneel	Respaldo
20	4R104290				•			Schienale	Châssis	Frame	Rückwand	Achterpaneel	Respaldo
20	4R104294					•		Schienale	Châssis	Frame	Rückwand	Achterpaneel	Respaldo
20	4R104298						•	Schienale	Châssis	Frame	Rückwand	Achterpaneel	Respaldo
24	4R104282		•					Pannello frontale	Panneau fronteau	Front panel	Frontplatte	Voorpaneel	Panel frontal
24	4R104287			•				Pannello frontale	Panneau fronteau	Front panel	Frontplatte	Voorpaneel	Panel frontal
24	4R104291				•			Pannello frontale	Panneau fronteau	Front panel	Frontplatte	Voorpaneel	Panel frontal
24	4R104295						•	Pannello frontale	Panneau fronteau	Front panel	Frontplatte	Voorpaneel	Panel frontal

N.	COD.	RC	20116254	20116244	20116246	20116250	20116252	DESCRIZIONE	DESCRIPTION	DESCRIPTION	BESCHREIBUNG	BESCHRIJVING	DESCRIPCIÓN	
24	4R104299						•	Pannello frontale	Panneau fronteau	Front panel	Frontplatte	Voorpaneel	Panel frontal	
33	4020818		•	•	•	•	•	Vaschetta raccolta condensa laterale	Cuvette réfléchissante	Drain pan	Schale	Bak	Cubeta	
37	4020819		•	•	•	•	•	Filtro	Filtre	Filter	Filtere	Filter	Filtro	300
38	4R003011		•	•	•	•	•	Filtro	Filtre	Filter	Filtere	Filter	Filtro	200
39	4R003014		•	•	•	•	•	Motore	Moteur	Motor	Motor	Motor	Motor	
40	4020821		•					Ventola tangenziale	Hélice tangentielle	Tangential air flow fan	Tangentiallüfterrad	Tangentiele aanjager	Impulsor tangencial	
40	4020830			•				Ventola tangenziale	Hélice tangentielle	Tangential air flow fan	Tangentiallüfterrad	Tangentiele aanjager	Impulsor tangencial	
40	4020836				•			Ventola tangenziale	Hélice tangentielle	Tangential air flow fan	Tangentiallüfterrad	Tangentiele aanjager	Impulsor tangencial	
40	4020842					•		Ventola tangenziale	Hélice tangentielle	Tangential air flow fan	Tangentiallüfterrad	Tangentiele aanjager	Impulsor tangencial	
40	4020848						•	Ventola tangenziale	Hélice tangentielle	Tangential air flow fan	Tangentiallüfterrad	Tangentiele aanjager	Impulsor tangencial	
44	4R000611		•	•	•	•	•	Supporto	Support	Bracket	Halterung	Steun	Soporte	
46	4020508		•	•	•	•	•	Cuscinetto ventola	Roulement hélice	Fan bearing	Lüfterradlager	Ventilatorlager	Cojinete impulsor	
47	4020624		•	•	•	•	•	Microinterruttore	Micro interrupteur	Micro switch	Mikroschalter	Microschakelaar	Microinterruptor	
52	4R000612		•	•	•	•	•	Tappo vaschetta	Bouchon	Plug	Deckel	Dop	Tapón	
53	4R104283		•					Traversa posteriore	Traverse	Bracket	Querstrebe	Onderbalk	Travesaño	
53	4R104288			•				Traversa posteriore	Traverse	Bracket	Querstrebe	Onderbalk	Travesaño	
53	4R104292				•			Traversa posteriore	Traverse	Bracket	Querstrebe	Onderbalk	Travesaño	
53	4R104296					•		Traversa posteriore	Traverse	Bracket	Querstrebe	Onderbalk	Travesaño	
53	4R104300						•	Traversa posteriore	Traverse	Bracket	Querstrebe	Onderbalk	Travesaño	
57	4R003017		•					Griglia superiore	Grille	Guard	Oberes Gitter	Bovenste rooster	Rejilla superior	
57	4R003018			•				Griglia superiore	Grille	Guard	Oberes Gitter	Bovenste rooster	Rejilla superior	
57	4R003019				•			Griglia superiore	Grille	Guard	Oberes Gitter	Bovenste rooster	Rejilla superior	
57	4R003020					•		Griglia superiore	Grille	Guard	Oberes Gitter	Bovenste rooster	Rejilla superior	
57	4R003021						•	Griglia superiore	Grille	Guard	Oberes Gitter	Bovenste rooster	Rejilla superior	
58	4020823		•					Vaschetta raccolta condensa	Cuvette réfléchissante	Drain pan	Schale	Bak	Cubeta	

N.	COD.	RC	20116254	20116244	20116246	20116250	20116252	DESCRIZIONE	DESCRIPTION	DESCRIPTION	BESCHREIBUNG	BESCHRIJVING	DESCRIPCIÓN
58	4020831			•				Vaschetta raccolta condensa	Cuvette réfléchissante	Drain pan	Schale	Bak	Cubeta
58	4020837				•			Vaschetta raccolta condensa	Cuvette réfléchissante	Drain pan	Schale	Bak	Cubeta
58	4R000621					•		Vaschetta raccolta condensa	Cuvette réfléchissante	Drain pan	Schale	Bak	Cubeta
58	4R000615					•		Vaschetta raccolta condensa	Cuvette réfléchissante	Drain pan	Schale	Bak	Cubeta
60	4R104284		•	•	•	•	•	Sonda acqua	Sonde eau	Water probe	Wasserfühler	Sonde	Sonda del agua
61	4020850						•	Ventola tangenziale	Hélice tangentielle	Tangential air flow fan	Tangentiallüfterrad	Tangentiele aanjager	Impulsor tangencial
62	4R102961		•					Isolamento superiore	Isolation supérieure	Top insulation	Obere Isolierung	Bovenste isolatie	Aislamiento superior
62	4R102962			•				Isolamento superiore	Isolation supérieure	Top insulation	Obere Isolierung	Bovenste isolatie	Aislamiento superior
62	4R102963				•			Isolamento superiore	Isolation supérieure	Top insulation	Obere Isolierung	Bovenste isolatie	Aislamiento superior
62	4R102964					•		Isolamento superiore	Isolation supérieure	Top insulation	Obere Isolierung	Bovenste isolatie	Aislamiento superior
62	4R102965						•	Isolamento superiore	Isolation supérieure	Top insulation	Obere Isolierung	Bovenste isolatie	Aislamiento superior
63	4R102661		•	•	•	•	•	Copertura	Couvercle	Cover	Abdeckung	Afdekking	Cubierta



N.	COD.	RC	20116258	20116260	20116261	20116263	20116264	DESCRIZIONE	DESCRIPTION	DESCRIPTION	BESCHREIBUNG	BESCHRIJVING	DESCRIPCIÓN
1	4020813		•					Batteria	Batterie	Condenser	Batterie	Accu	Batería
1	4020826			•				Batteria	Batterie	Condenser	Batterie	Accu	Batería
1	4020832				•			Batteria	Batterie	Condenser	Batterie	Accu	Batería
1	4020838					•		Batteria	Batterie	Condenser	Batterie	Accu	Batería
1	4020844						•	Batteria	Batterie	Condenser	Batterie	Accu	Batería
9	4R000640		•					Isolante traversa superiore	Isolation	Protection	Isolierung	Isolatie	Aislante
9	4R000634			•				Isolante traversa superiore	Isolation	Protection	Isolierung	Isolatie	Aislante
9	4R000628				•			Isolante traversa superiore	Isolation	Protection	Isolierung	Isolatie	Aislante
9	4R000622					•		Isolante traversa superiore	Isolation	Protection	Isolierung	Isolatie	Aislante
9	4R000614						•	Isolante traversa superiore	Isolation	Protection	Isolierung	Isolatie	Aislante
10	4R104278		•	•	•	•	•	Fiancata destra	Habillage droit	Right side	Rechte Seitenwand	Rechter zijwand	Panel lateral derecho
11	4R104279		•	•	•	•	•	Fiancata sinistra	Habillage gauche	Left side	Linke Seitenwand	Linker zijwand	Panel lateral izquierdo
14	4R003050		•					Griglia	Grille	Guard	Gitter	Rooster	Rejilla
14	4R003058			•				Griglia	Grille	Guard	Gitter	Rooster	Rejilla
14	4R003059				•			Griglia	Grille	Guard	Gitter	Rooster	Rejilla
14	4R003061					•		Griglia	Grille	Guard	Gitter	Rooster	Rejilla
14	4R003063						•	Griglia	Grille	Guard	Gitter	Rooster	Rejilla
20	4R104281		•					Schienale	Châssis	Frame	Rückwand	Achterpaneel	Respaldo
20	4R104286			•				Schienale	Châssis	Frame	Rückwand	Achterpaneel	Respaldo
20	4R104290				•			Schienale	Châssis	Frame	Rückwand	Achterpaneel	Respaldo
20	4R104294					•		Schienale	Châssis	Frame	Rückwand	Achterpaneel	Respaldo
20	4R104298						•	Schienale	Châssis	Frame	Rückwand	Achterpaneel	Respaldo
22	4R003051		•	•	•	•	•	Levismo sinistro	Leviers	Lifting assembly	Regulierung	Hendelstelsel	Mecanismo de Palancas
23	4R003052		•	•	•	•	•	Levismo destro	Leviers	Lifting assembly	Regulierung	Hendelstelsel	Mecanismo de Palancas
24	4R104301		•					Pannello frontale	Panneau frontale	Front panel	Frontplatte	Voorpaneel	Panel frontal
24	4R104302			•				Pannello frontale	Panneau frontale	Front panel	Frontplatte	Voorpaneel	Panel frontal
24	4R104303				•			Pannello frontale	Panneau frontale	Front panel	Frontplatte	Voorpaneel	Panel frontal

N.	COD.	RC	20116258	20116260	20116261	20116263	20116264	DESCRIZIONE	DESCRIPTION	DESCRIPTION	BESCHREIBUNG	BESCHRIJVING	DESCRIPCIÓN	
24	4R104304						•	Pannello frontale	Panneau fronteau	Front panel	Frontplatte	Voorpaneel	Panel frontal	
24	4R104305						•	Pannello frontale	Panneau fronteau	Front panel	Frontplatte	Voorpaneel	Panel frontal	
33	4020818		•	•	•	•	•	Vaschetta raccolta condensa laterale	Cuvette réfléchissante	Drain pan	Schale	Bak	Cubeta	
37	4020819		•	•	•	•	•	Filtro	Filtre	Filter	Filtere	Filter	Filtro	300
38	4R003011		•	•	•	•	•	Filtro	Filtre	Filter	Filtere	Filter	Filtro	200
39	4R003014		•	•	•	•	•	Motore	Moteur	Motor	Motor	Motor	Motor	
40	4020821		•					Ventola tangenziale	Hélice tangentielle	Tangential air flow fan	Tangentiallüfterrad	Tangentiele aanjager	Impulsor tangencial	
40	4020830			•				Ventola tangenziale	Hélice tangentielle	Tangential air flow fan	Tangentiallüfterrad	Tangentiele aanjager	Impulsor tangencial	
40	4020836				•			Ventola tangenziale	Hélice tangentielle	Tangential air flow fan	Tangentiallüfterrad	Tangentiele aanjager	Impulsor tangencial	
40	4020842					•		Ventola tangenziale	Hélice tangentielle	Tangential air flow fan	Tangentiallüfterrad	Tangentiele aanjager	Impulsor tangencial	
40	4020848					•		Ventola tangenziale	Hélice tangentielle	Tangential air flow fan	Tangentiallüfterrad	Tangentiele aanjager	Impulsor tangencial	
44	4R000611		•	•	•	•	•	Supporto	Support	Bracket	Halterung	Steun	Soporte	
46	4020508		•	•	•	•	•	Cuscinetto ventola	Roulement hélice	Fan bearing	Lüfterradlager	Ventilatorlager	Cojinete impulsor	
52	4R000612		•	•	•	•	•	Tappo vaschetta	Bouchon	Plug	Deckel	Dop	Tapón	
53	4R104283		•					Traversa posteriore	Traverse	Bracket	Querstrebe	Onderbalk	Travesaño	
53	4R104288			•				Traversa posteriore	Traverse	Bracket	Querstrebe	Onderbalk	Travesaño	
53	4R104292				•			Traversa posteriore	Traverse	Bracket	Querstrebe	Onderbalk	Travesaño	
53	4R104296					•		Traversa posteriore	Traverse	Bracket	Querstrebe	Onderbalk	Travesaño	
53	4R104300					•		Traversa posteriore	Traverse	Bracket	Querstrebe	Onderbalk	Travesaño	
57	4R003017		•					Griglia superiore	Grille	Guard	Oberes Gitter	Bovenste rooster	Rejilla superior	
57	4R003018			•				Griglia superiore	Grille	Guard	Oberes Gitter	Bovenste rooster	Rejilla superior	
57	4R003019				•			Griglia superiore	Grille	Guard	Oberes Gitter	Bovenste rooster	Rejilla superior	
57	4R003020					•		Griglia superiore	Grille	Guard	Oberes Gitter	Bovenste rooster	Rejilla superior	
57	4R003021					•		Griglia superiore	Grille	Guard	Oberes Gitter	Bovenste rooster	Rejilla superior	
58	4020823		•					Vaschetta raccolta condensa	Cuvette réfléchissante	Drain pan	Schale	Bak	Cubeta	



N.	COD.	RC	20116258	20116260	20116261	20116263	20116264	DESCRIZIONE	DESCRIPTION	DESCRIPTION	BESCHREIBUNG	BESCHRIJVING	DESCRIPCIÓN
58	4020831			•				Vaschetta raccolta condensa	Cuvette réfléchissante	Drain pan	Schale	Bak	Cubeta
58	4020837				•			Vaschetta raccolta condensa	Cuvette réfléchissante	Drain pan	Schale	Bak	Cubeta
58	4R000621					•		Vaschetta raccolta condensa	Cuvette réfléchissante	Drain pan	Schale	Bak	Cubeta
58	4R000615					•		Vaschetta raccolta condensa	Cuvette réfléchissante	Drain pan	Schale	Bak	Cubeta
60	4R104284		•	•	•	•	•	Sonda acqua	Sonde eau	Water probe	Wasserfühler	Sonde	Sonda del agua
61	4020850						•	Ventola tangenziale	Hélice tangentielle	Tangential air flow fan	Tangentiallüfterrad	Tangentiele aanjager	Impulsor tangencial
63	4R102661		•	•	•	•	•	Copertura	Couvercle	Cover	Abdeckung	Afdekking	Cubierta
65	4R003053		•					Pannello frontale isolato	Panneau frontale	Front panel	Frontplatte	Voorpaneel	Panel frontal
65	4R003057			•				Pannello frontale isolato	Panneau frontale	Front panel	Frontplatte	Voorpaneel	Panel frontal
65	4R003060				•			Pannello frontale isolato	Panneau frontale	Front panel	Frontplatte	Voorpaneel	Panel frontal
65	4R003062					•		Pannello frontale isolato	Panneau frontale	Front panel	Frontplatte	Voorpaneel	Panel frontal
65	4R003064						•	Pannello frontale isolato	Panneau frontale	Front panel	Frontplatte	Voorpaneel	Panel frontal
66	4R102042		•	•	•	•	•	Ventilatore	Ventilateur	Fan	Lüfter	Ventilator	Ventilador
67	4R003055		•	•	•	•	•	Supporto	Support	Bracket	Halter	Steun	Soporte
68	4R102043		•	•	•	•	•	Alimentatore	Alimentateur	Power supply unit	Speiser	Voeder	Alimentador

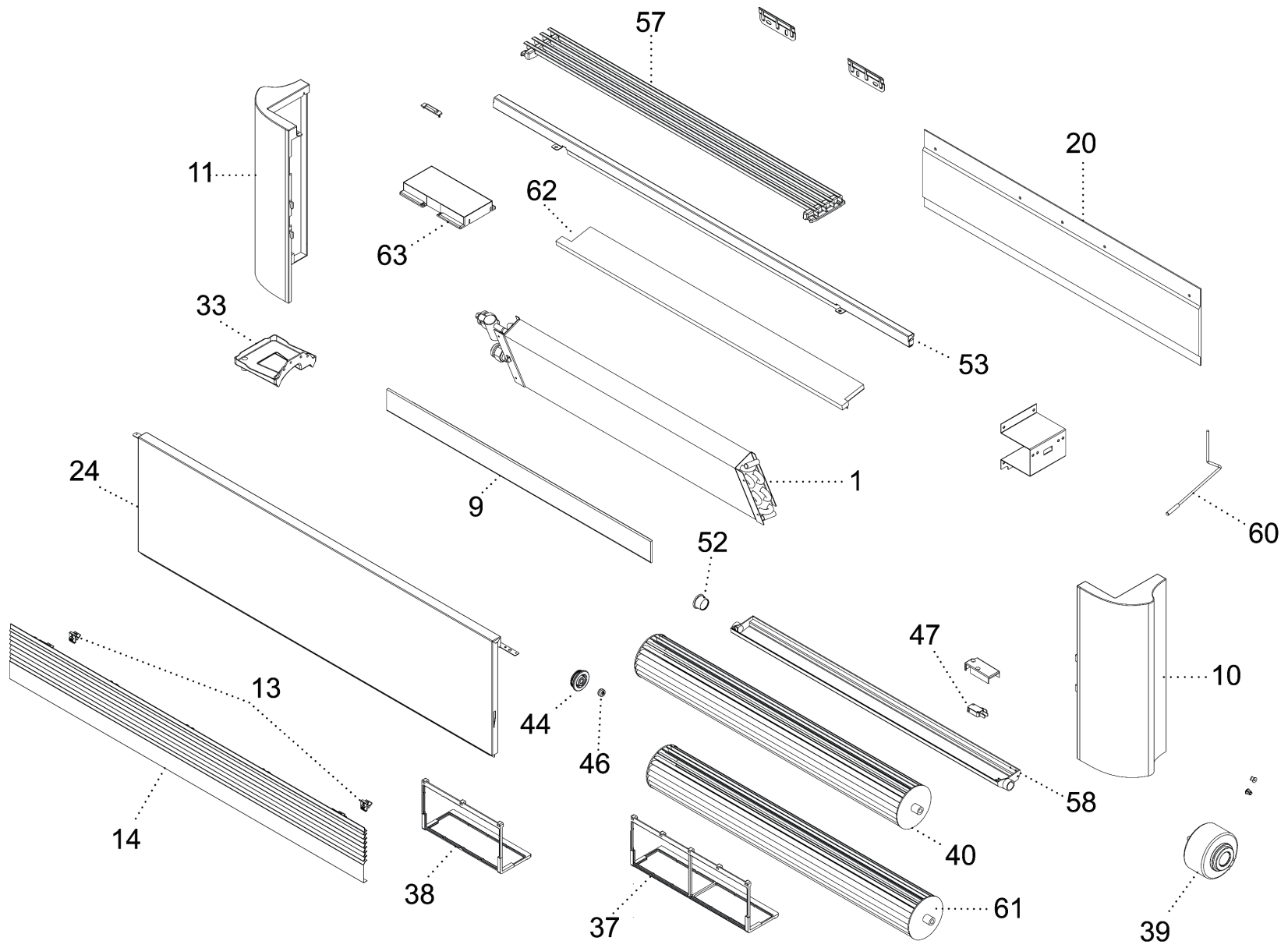

N.	COD.	RC	20116265	20116267	20116271	20116272	20116273	DESCRIZIONE	DESCRIPTION	DESCRIPTION	BESCHREIBUNG	BESCHRIJVING	DESCRIPCIÓN
1	4R003026		•					Batteria	Batterie	Condenser	Batterie	Accu	Batería
1	4R003013			•				Batteria	Batterie	Condenser	Batterie	Accu	Batería
1	4R100096				•			Batteria	Batterie	Condenser	Batterie	Accu	Batería
1	4R100099					•		Batteria	Batterie	Condenser	Batterie	Accu	Batería
1	4R100102						•	Batteria	Batterie	Condenser	Batterie	Accu	Batería
9	4R000640		•					Isolante traversa superiore	Isolation	Protection	Isolierung	Isolatie	Aislante
9	4R000634			•				Isolante traversa superiore	Isolation	Protection	Isolierung	Isolatie	Aislante
9	4R000628				•			Isolante traversa superiore	Isolation	Protection	Isolierung	Isolatie	Aislante
9	4R000622					•		Isolante traversa superiore	Isolation	Protection	Isolierung	Isolatie	Aislante
9	4R000614						•	Isolante traversa superiore	Isolation	Protection	Isolierung	Isolatie	Aislante
10	4R104306		•	•	•	•	•	Fiancata destra	Habillage droit	Right side	Rechte Seitenwand	Rechter zijwand	Panel lateral derecho
11	4R104307		•	•	•	•	•	Fiancata sinistra	Habillage gauche	Left side	Linke Seitenwand	Linker zijwand	Panel lateral izquierdo
13	4R003010		•	•	•	•	•	Gancio griglia	Crochet	Hooks	Haken	Haak	Gancho
14	4R104280		•					Griglia	Grille	Guard	Gitter	Rooster	Rejilla
14	4R104285			•				Griglia	Grille	Guard	Gitter	Rooster	Rejilla
14	4R104289				•			Griglia	Grille	Guard	Gitter	Rooster	Rejilla
14	4R104311					•		Griglia	Grille	Guard	Gitter	Rooster	Rejilla
14	4R104297						•	Griglia	Grille	Guard	Gitter	Rooster	Rejilla
20	4R003025		•					Schienale	Châssis	Frame	Rückwand	Achterpaneel	Respaldo
20	4R003029			•				Schienale	Chassis	Frame	Rückwand	Achterpaneel	Respaldo
20	4R100097				•			Schienale	Chassis	Frame	Rückwand	Achterpaneel	Respaldo
20	4R100100					•		Schienale	Chassis	Frame	Rückwand	Achterpaneel	Respaldo
20	4R100103						•	Schienale	Chassis	Frame	Rückwand	Achterpaneel	Respaldo
24	4R104308		•					Pannello frontale	Panneau frontale	Front panel	Frontplatte	Voorpaneel	Panel frontal
24	4R104309			•				Pannello frontale	Panneau frontale	Front panel	Frontplatte	Voorpaneel	Panel frontal
24	4R104310				•			Pannello frontale	Panneau frontale	Front panel	Frontplatte	Voorpaneel	Panel frontal
24	4R104312					•		Pannello frontale	Panneau frontale	Front panel	Frontplatte	Voorpaneel	Panel frontal

N.	COD.	RC	20116265	20116267	20116271	20116272	20116273	DESCRIZIONE	DESCRIPTION	DESCRIPTION	BESCHREIBUNG	BESCHRIJVING	DESCRIPCIÓN	
24	4R104313							● Pannello frontale	Panneau fronteau	Front panel	Frontplatte	Voorpaneel	Panel frontal	
33	4020818		●	●	●	●	●	Vaschetta raccolta condensa laterale	Cuvette réfléchissante	Drain pan	Schale	Bak	Cubeta	
37	4020819		●	●	●	●	●	Filtro	Filtre	Filter	Filtere	Filter	Filtro	300
38	4R003011		●	●	●	●	●	Filtro	Filtre	Filter	Filtere	Filter	Filtro	200
39	4R003014		●	●	●	●	●	Motore	Moteur	Motor	Motor	Motor	Motor	
40	4020821		●					Ventola tangenziale	Hélice tangentielle	Tangential air flow fan	Tangentiallüfterrad	Tangentiele aanjager	Impulsor tangencial	
40	4020830			●				Ventola tangenziale	Hélice tangentielle	Tangential air flow fan	Tangentiallüfterrad	Tangentiele aanjager	Impulsor tangencial	
40	4020836				●			Ventola tangenziale	Hélice tangentielle	Tangential air flow fan	Tangentiallüfterrad	Tangentiele aanjager	Impulsor tangencial	
40	4020842					●		Ventola tangenziale	Hélice tangentielle	Tangential air flow fan	Tangentiallüfterrad	Tangentiele aanjager	Impulsor tangencial	
40	4020848						●	Ventola tangenziale	Hélice tangentielle	Tangential air flow fan	Tangentiallüfterrad	Tangentiele aanjager	Impulsor tangencial	
44	4R000611		●	●	●	●	●	Supporto	Support	Bracket	Halterung	Steun	Soporte	
46	4020508		●	●	●	●	●	Cuscinetto ventola	Roulement hélice	Fan bearing	Lüfterradlager	Ventilatorlager	Cojinete impulsor	
47	4020624		●	●	●	●	●	Microinterruttore	Micro interrupteur	Micro switch	Mikroschalter	Microschakelaar	Microinterruptor	
52	4R000612		●	●	●	●	●	Tappo vaschetta	Bouchon	Plug	Deckel	Dop	Tapón	
53	4R104283		●					Traversa posteriore	Traverse	Bracket	Querstrebe	Onderbalk	Travesaño	
53	4R104288			●				Traversa posteriore	Traverse	Bracket	Querstrebe	Onderbalk	Travesaño	
53	4R104292				●			Traversa posteriore	Traverse	Bracket	Querstrebe	Onderbalk	Travesaño	
53	4R104296					●		Traversa posteriore	Traverse	Bracket	Querstrebe	Onderbalk	Travesaño	
53	4R104300						●	Traversa posteriore	Traverse	Bracket	Querstrebe	Onderbalk	Travesaño	
57	4R003017		●					Griglia superiore	Grille	Guard	Oberes Gitter	Bovenste rooster	Rejilla superior	
57	4R003018			●				Griglia superiore	Grille	Guard	Oberes Gitter	Bovenste rooster	Rejilla superior	
57	4R003019				●			Griglia superiore	Grille	Guard	Oberes Gitter	Bovenste rooster	Rejilla superior	
57	4R003020					●		Griglia superiore	Grille	Guard	Oberes Gitter	Bovenste rooster	Rejilla superior	
57	4R003021						●	Griglia superiore	Grille	Guard	Oberes Gitter	Bovenste rooster	Rejilla superior	
58	4020823		●					Vaschetta raccolta condensa	Cuvette réfléchissante	Drain pan	Schale	Bak	Cubeta	

N.	COD.	RC	20116265	20116267	20116271	20116272	20116273	DESCRIZIONE	DESCRIPTION	DESCRIPTION	BESCHREIBUNG	BESCHRIJVING	DESCRIPCIÓN
58	4020831			•				Vaschetta raccolta condensa	Cuvette réfléchissante	Drain pan	Schale	Bak	Cubeta
58	4020837				•			Vaschetta raccolta condensa	Cuvette réfléchissante	Drain pan	Schale	Bak	Cubeta
58	4R000621					•		Vaschetta raccolta condensa	Cuvette réfléchissante	Drain pan	Schale	Bak	Cubeta
58	4R000615					•		Vaschetta raccolta condensa	Cuvette réfléchissante	Drain pan	Schale	Bak	Cubeta
60	4R104284		•	•	•	•	•	Sonda acqua	Sonde eau	Water probe	Wasserrührer	Sonde	Sonda del agua
61	4020850						•	Ventola tangenziale	Hélice tangentielle	Tangential air flow fan	Tangentiallüfterrad	Tangentiele aanjager	Impulsor tangencial
62	4R102961		•					Isolamento superiore	Isolation supérieure	Top insulation	Obere Isolierung	Bovenste isolatie	Aislamiento superior
62	4R102962			•				Isolamento superiore	Isolation supérieure	Top insulation	Obere Isolierung	Bovenste isolatie	Aislamiento superior
62	4R102963				•			Isolamento superiore	Isolation supérieure	Top insulation	Obere Isolierung	Bovenste isolatie	Aislamiento superior
62	4R102964					•		Isolamento superiore	Isolation supérieure	Top insulation	Obere Isolierung	Bovenste isolatie	Aislamiento superior
62	4R102965						•	Isolamento superiore	Isolation supérieure	Top insulation	Obere Isolierung	Bovenste isolatie	Aislamiento superior
63	4R102661		•	•	•	•	•	Copertura	Couvercle	Cover	Abdeckung	Afdekking	Cubierta

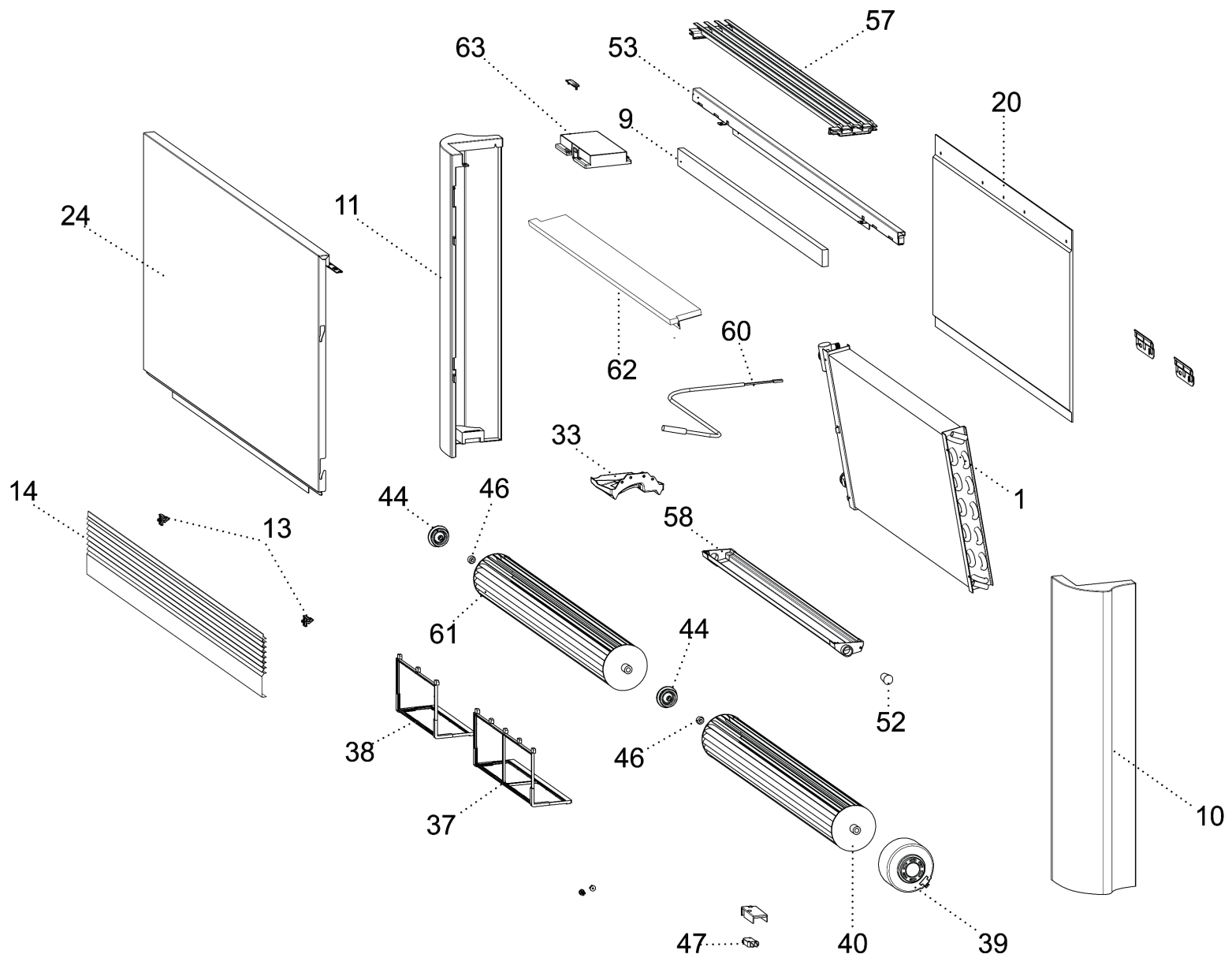

N.	COD.	RC	20116845	20116924	20116925	20116928	20116929	DESCRIZIONE	DESCRIPTION	DESCRIPTION	BESCHREIBUNG	BESCHRIJVING	DESCRIPCIÓN
1	4020813		•					Batteria	Batterie	Condenser	Batterie	Accu	Batería
1	4020826			•				Batteria	Batterie	Condenser	Batterie	Accu	Batería
1	4020832				•			Batteria	Batterie	Condenser	Batterie	Accu	Batería
1	4020838					•		Batteria	Batterie	Condenser	Batterie	Accu	Batería
1	4020844						•	Batteria	Batterie	Condenser	Batterie	Accu	Batería
9	4R000640		•					Isolante traversa superiore	Isolation	Protection	Isolierung	Isolatie	Aislante
9	4R000634			•				Isolante traversa superiore	Isolation	Protection	Isolierung	Isolatie	Aislante
9	4R000628				•			Isolante traversa superiore	Isolation	Protection	Isolierung	Isolatie	Aislante
9	4R000622					•		Isolante traversa superiore	Isolation	Protection	Isolierung	Isolatie	Aislante
9	4R000614						•	Isolante traversa superiore	Isolation	Protection	Isolierung	Isolatie	Aislante
10	4R003022		•	•	•	•	•	Pannello laterale Dx	Panneau latéral de droite	Right side	Rechte Seitenwand	Voorste zijpaneel	Panel lateral
11	4R003024		•	•	•	•	•	Pannello laterale Sx	Panneau latéral de gauche	Left side	Linke Seitenwand	Linker zijpaneel	Lateral izquierdo
13	4R003010		•	•	•	•	•	Gancio griglia	Crochet	Hooks	Haken	Haak	Gancho
14	4R104314		•					Griglia	Grille	Guard	Gitter	Rooster	Rejilla
14	4R104316			•				Griglia	Grille	Guard	Gitter	Rooster	Rejilla
14	4R104318				•			Griglia	Grille	Guard	Gitter	Rooster	Rejilla
14	4R104320					•		Griglia	Grille	Guard	Gitter	Rooster	Rejilla
14	4R104322						•	Griglia	Grille	Guard	Gitter	Rooster	Rejilla
20	4R104281		•					Schienale	Châssis	Frame	Rückwand	Achterpaneel	Respaldo
20	4R104286			•				Schienale	Châssis	Frame	Rückwand	Achterpaneel	Respaldo
20	4R104290				•			Schienale	Châssis	Frame	Rückwand	Achterpaneel	Respaldo
20	4R104294					•		Schienale	Châssis	Frame	Rückwand	Achterpaneel	Respaldo
20	4R104298						•	Schienale	Châssis	Frame	Rückwand	Achterpaneel	Respaldo
24	4R104315		•					Pannello frontale	Panneau fronteau	Front panel	Frontplatte	Voorpaneel	Panel frontal
24	4R104317			•				Pannello frontale	Panneau fronteau	Front panel	Frontplatte	Voorpaneel	Panel frontal
24	4R104319				•			Pannello frontale	Panneau fronteau	Front panel	Frontplatte	Voorpaneel	Panel frontal
24	4R104321					•		Pannello frontale	Panneau fronteau	Front panel	Frontplatte	Voorpaneel	Panel frontal

N.	COD.	RC	20116845	20116924	20116925	20116928	20116929	DESCRIZIONE	DESCRIPTION	DESCRIPTION	BESCHREIBUNG	BESCHRIJVING	DESCRIPCIÓN	
24	4R104323						•	Pannello frontale	Panneau fronteau	Front panel	Frontplatte	Voorpaneel	Panel frontal	
33	4020818		•	•	•	•	•	Vaschetta raccolta condensa laterale	Cuvette réfléchissante	Drain pan	Schale	Bak	Cubeta	
37	4020819		•	•	•	•	•	Filtro	Filtre	Filter	Filtere	Filter	Filtro	300
38	4R003011		•	•	•	•	•	Filtro	Filtre	Filter	Filtere	Filter	Filtro	200
39	4R003014		•	•	•	•	•	Motore	Moteur	Motor	Motor	Motor	Motor	
40	4020821		•					Ventola tangenziale	Hélice tangentielle	Tangential air flow fan	Tangentiallüfterrad	Tangentiele aanjager	Impulsor tangencial	
40	4020830			•				Ventola tangenziale	Hélice tangentielle	Tangential air flow fan	Tangentiallüfterrad	Tangentiele aanjager	Impulsor tangencial	
40	4020836				•			Ventola tangenziale	Hélice tangentielle	Tangential air flow fan	Tangentiallüfterrad	Tangentiele aanjager	Impulsor tangencial	
40	4020842					•		Ventola tangenziale	Hélice tangentielle	Tangential air flow fan	Tangentiallüfterrad	Tangentiele aanjager	Impulsor tangencial	
40	4020848						•	Ventola tangenziale	Hélice tangentielle	Tangential air flow fan	Tangentiallüfterrad	Tangentiele aanjager	Impulsor tangencial	
44	4R000611		•	•	•	•	•	Supporto	Support	Bracket	Halterung	Steun	Soporte	
46	4020508		•	•	•	•	•	Cuscinetto ventola	Roulement hélice	Fan bearing	Lüfterradlager	Ventilatorlager	Cojinete impulsor	
47	4020624		•	•	•	•	•	Microinterruttore	Micro interrupteur	Micro switch	Mikroschalter	Microschakelaar	Microinterruptor	
52	4R000612		•	•	•	•	•	Tappo vaschetta	Bouchon	Plug	Deckel	Dop	Tapón	
53	4R003040		•					Traversa	Traverse	Bracket	Querstrebe	Onderbalk	Travesaño	
53	4R003042			•				Traversa	Traverse	Bracket	Querstrebe	Onderbalk	Travesaño	
53	4R003044				•			Traversa	Traverse	Bracket	Querstrebe	Onderbalk	Travesaño	
53	4R003046					•		Traversa	Traverse	Bracket	Querstrebe	Onderbalk	Travesaño	
53	4R003048						•	Traversa	Traverse	Bracket	Querstrebe	Onderbalk	Travesaño	
57	4R003017		•					Griglia superiore	Grille	Guard	Oberes Gitter	Bovenste rooster	Rejilla superior	
57	4R003018			•				Griglia superiore	Grille	Guard	Oberes Gitter	Bovenste rooster	Rejilla superior	
57	4R003019				•			Griglia superiore	Grille	Guard	Oberes Gitter	Bovenste rooster	Rejilla superior	
57	4R003020					•		Griglia superiore	Grille	Guard	Oberes Gitter	Bovenste rooster	Rejilla superior	
57	4R003021						•	Griglia superiore	Grille	Guard	Oberes Gitter	Bovenste rooster	Rejilla superior	
58	4020823		•					Vaschetta raccolta condensa	Cuvette réfléchissante	Drain pan	Schale	Bak	Cubeta	



N.	COD.	RC						DESCRIZIONE	DESCRIPTION	DESCRIPTION	BESCHREIBUNG	BESCHRIJVING	DESCRIPCIÓN
			20116845	20116924	20116925	20116928	20116929						
58	4020831			•			Vaschetta raccolta condensa	Cuvette réfléchissante	Drain pan	Schale	Bak	Cubeta	
58	4020837				•		Vaschetta raccolta condensa	Cuvette réfléchissante	Drain pan	Schale	Bak	Cubeta	
58	4R000621					•	Vaschetta raccolta condensa	Cuvette réfléchissante	Drain pan	Schale	Bak	Cubeta	
58	4R000615					•	Vaschetta raccolta condensa	Cuvette réfléchissante	Drain pan	Schale	Bak	Cubeta	
60	4R104284		•	•	•	•	Sonda acqua	Sonde eau	Water probe	Wasserrührer	Sonde	Sonda del agua	
61	4020850					•	Ventola tangenziale	Hélice tangentielle	Tangential air flow fan	Tangentiallüfterrad	Tangentiele aanjager	Impulsor tangencial	
62	4R102961		•				Isolamento superiore	Isolation supérieure	Top insulation	Obere Isolierung	Bovenste isolatie	Aislamiento superior	
62	4R102962			•			Isolamento superiore	Isolation supérieure	Top insulation	Obere Isolierung	Bovenste isolatie	Aislamiento superior	
62	4R102963				•		Isolamento superiore	Isolation supérieure	Top insulation	Obere Isolierung	Bovenste isolatie	Aislamiento superior	
62	4R102964					•	Isolamento superiore	Isolation supérieure	Top insulation	Obere Isolierung	Bovenste isolatie	Aislamiento superior	
62	4R102965					•	Isolamento superiore	Isolation supérieure	Top insulation	Obere Isolierung	Bovenste isolatie	Aislamiento superior	
63	4R102661		•	•	•	•	Copertura	Couvercle	Cover	Abdeckung	Afdekking	Cubierta	





---

# **RIELLO**

**Riello S.p.A.**  
**37045 Z.A.I. di San Pietro di Legnago (Verona) Via Ing. Pilade Riello, 7**  
**Tel. 0442/630.111 - Fax 0442/22378 <http://www.riello.it>**  
**archivio <http://ics.riello.it>**

---

La nostra azienda, nella costante azione migliorativa sul prodotto, si riserva la possibilità di modificare i dati riportati in questo documento in qualsiasi momento e senza preavviso. - Puisque l'entreprise cherche constamment à perfectionner toute sa production, les caractéristiques esthétiques et dimensionnelles, les données techniques, les équipements et les accessoires, peuvent subir des modifications. - The manufacturer strives to continuously improve all products. Appearance, dimensions, technical specifications, standard equipment and accessories are therefore liable to modification without notice. - Da das Unternehmen konstant um die Perfektionierung seiner Produktion bemüht ist, können das äußere Erscheinungsbild, die Abmessungen, die technischen Daten, die Ausstattungen sowie Zubehörteile Änderungen unterworfen werden. - In een voortdurend streven naar het verbeteren van onze producten, behouden wij ons het recht voor om de gegevens in dit document op elk moment te wijzigen, zonder kennisgeving vooraf. - Nuestra empresa dedica sus esfuerzos al constante perfeccionamiento de toda su producción; por eso las características estéticas y las dimensiones, los datos técnicos, los equipamientos y los accesorios pueden estar sometidos a variación. 9491