

Catalogo ricambi
Catalogue pièces détachées
Spare parts catalogue
Ersatzteilkatalog
Onderdelenlijst
Catálogo de recambios

RIELLO

Caldiae Murali
Chaudières murales
Wall hung boilers
Wandgastherme
Gaswandkessel
Calderas mural a gas

COD.

MOD.

TYP.

20190068

CONDEXA HPR 70

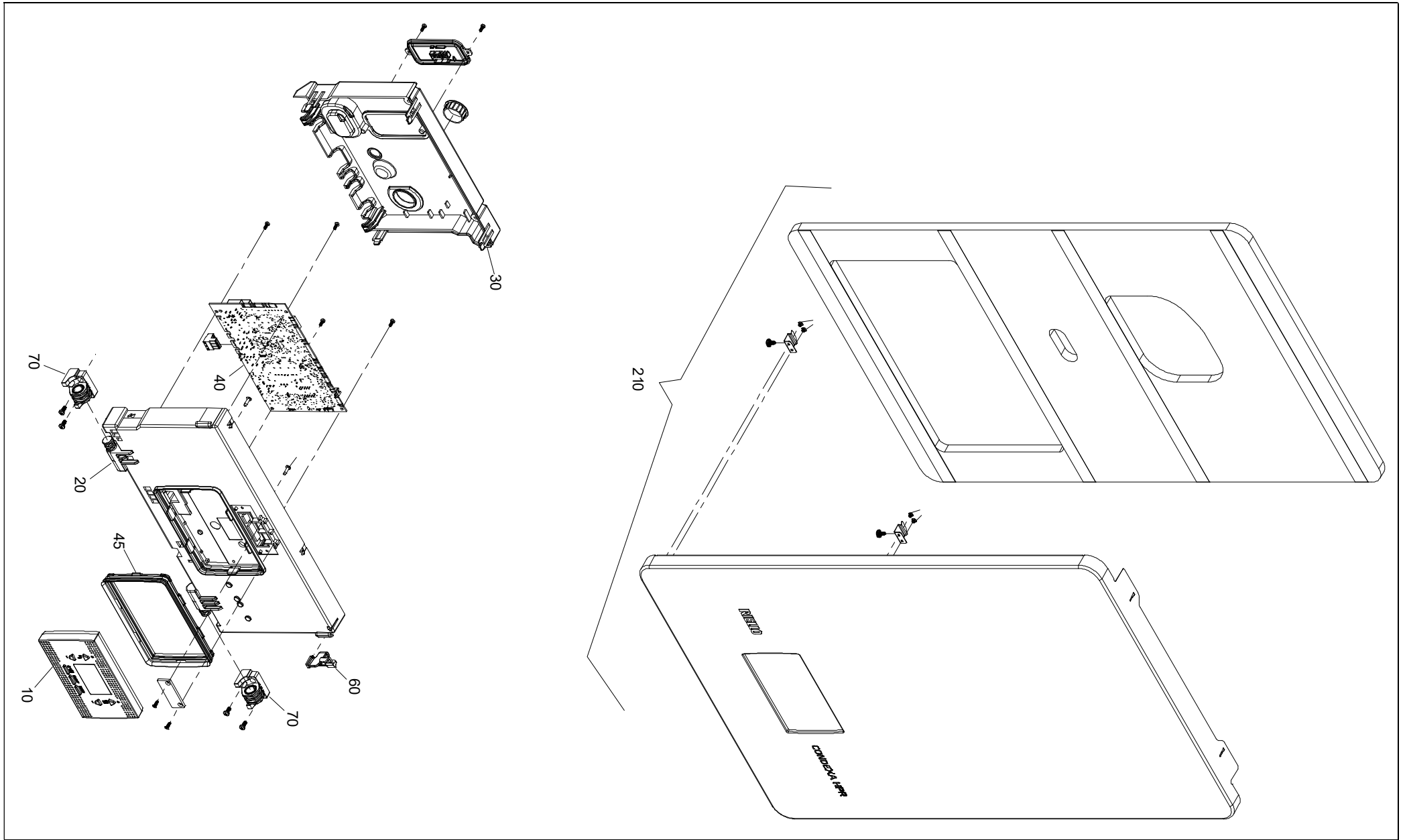

N.	COD.	RC 20190068	DESCRIZIONE	DESCRIPTION	DESCRIPTION	BESCHREIBUNG	BESCHRIJVING	DESCRIPCIÓN
10	20200198	•	Pannello comandi	Tableau de commande	Control panel	Verkleidung Steuerungen	Bedieningspaneel	Panel mandos
20	4R109975	•	Cruscotto	Tableau de bord	Instrument panel	Instrumentenbrett	Dashboard	Panel display
30	20198522	•	Copertura	Capot	Cover	Abdeckung	Kap	Tapa (cubierta)
40	20198523	•	Scheda gestione	Carte de gestion	Management PCB	Verwaltungskarte	Beheerkaart	Tarjeta de gestión
45	4R105461	•	Guarnizione	Joint	Seal	Dichtung	Afdichting	Junta
60	4R105513	•	Gancio	Crochet	Hook	Haken	Klem	Gancho
70	4R105512	•	Cerniera	Charniere	Hinge	Scharniereinheit	Scharnier	Cable señal PWM
210	20198448	•	Mantello	Jupe	Shell	Mantel	Mantel	Panel

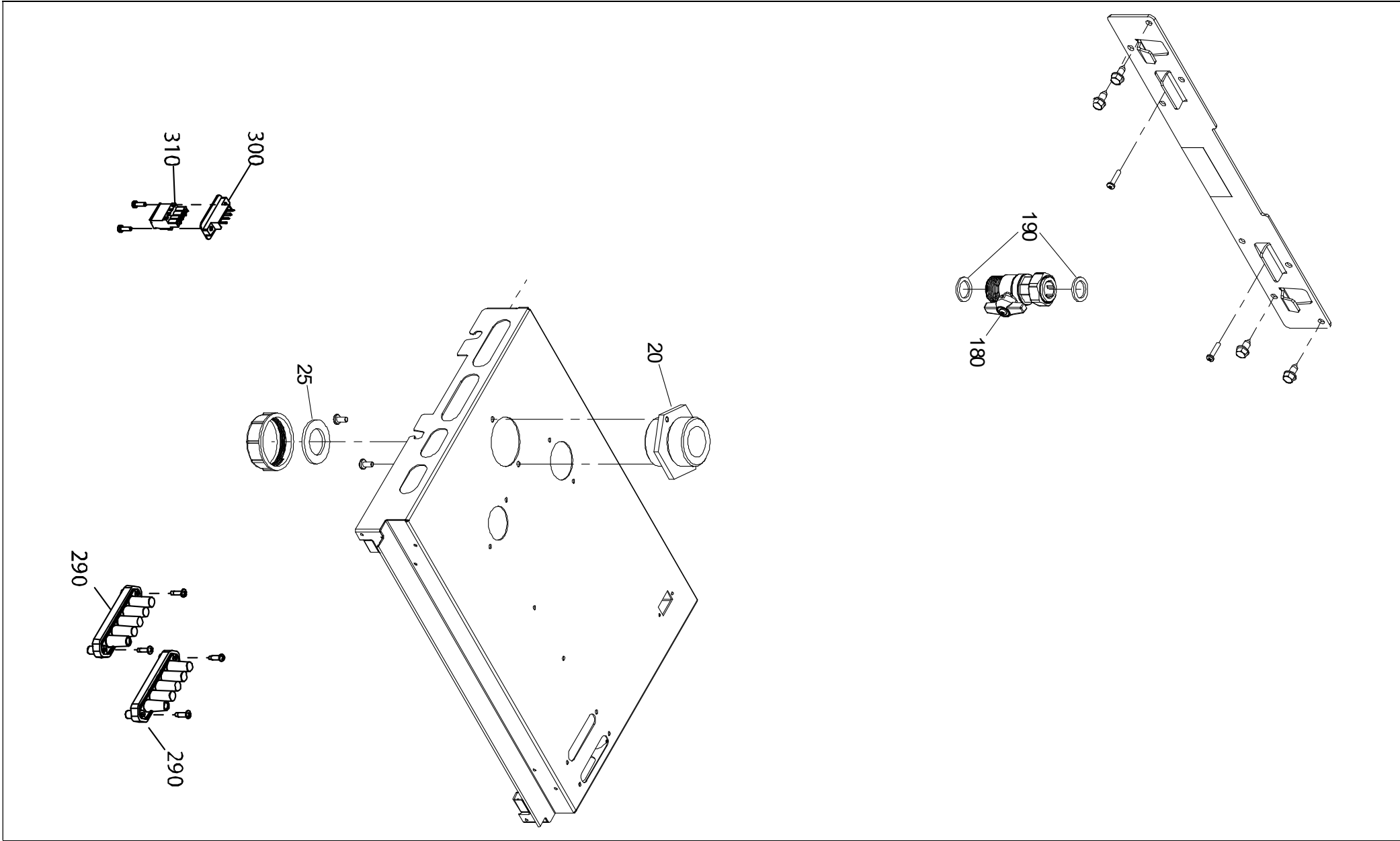

N.	COD.	RC	DESCRIZIONE	DESCRIPTION	DESCRIPTION	BESCHREIBUNG	BESCHRIJVING	DESCRIPCIÓN
20	20198805	20190068	• Nipple	Mamelon	Nipple	Nippel	Nippels	Manguito
25	20198543		• Guarnizione	Joint	Seal	Dichtung	Afdichting	Junta
180	4R108891		• Rubinetto gas	Robinet gaz	Gas cock	Gashahn	Gaskraan	Llave de gas
190	4363389		• Guarnizione	Joint	Seal	Dichtung	Afdichting	Junta
290	4R105529		• Passacavo	Passe cable	Cable grommet	Kabeldurchführung	Kabeldoorvoer	Pasacables
300	4R109838		• Connettore	Raccord	Connector	Steckverbinder	Aansluiting	Conector
310	4R107480		• Connettore	Raccord	Connector	Steckverbinder	Aansluiting	Conector

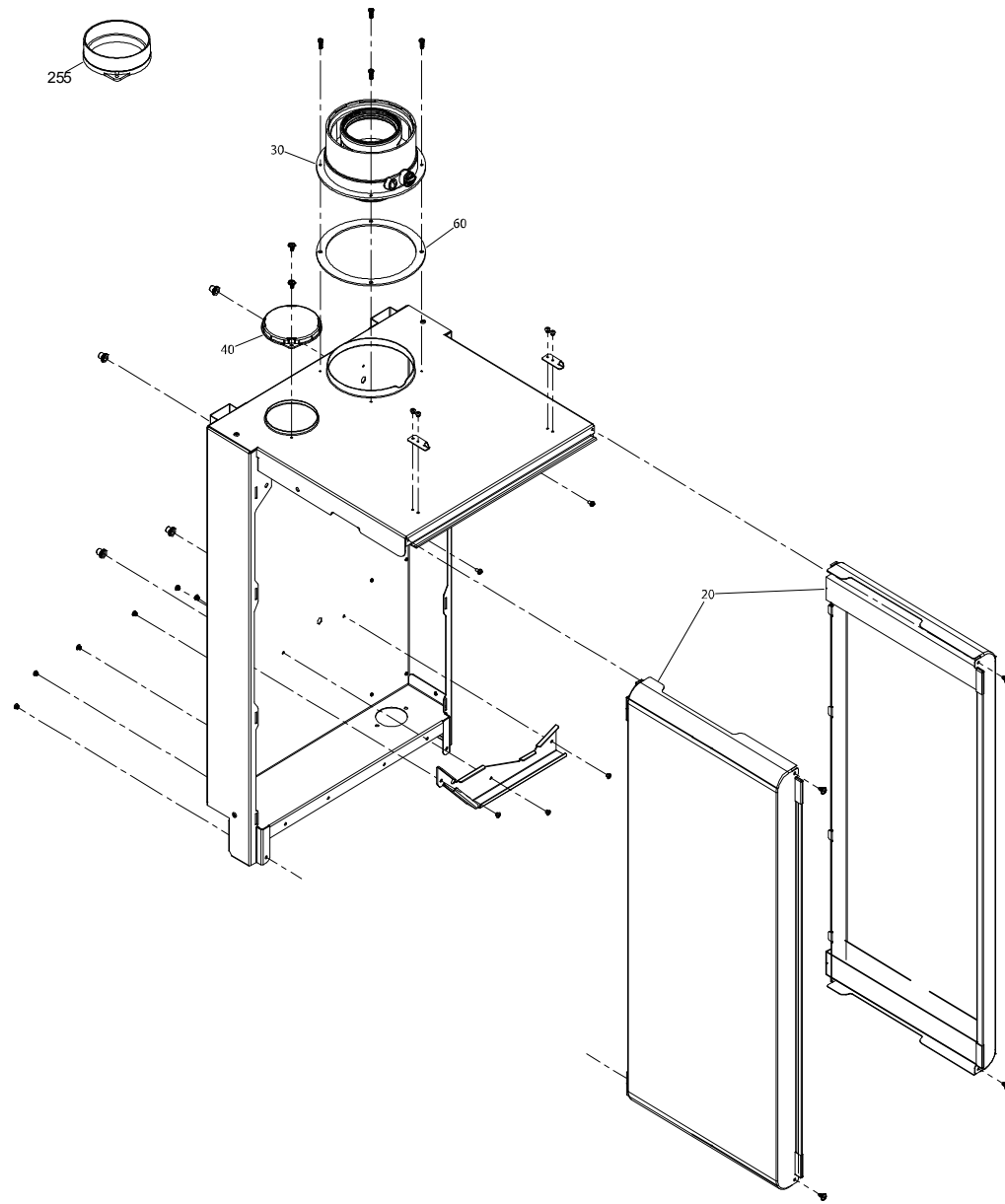

N.	COD.	RC	DESCRIZIONE	DESCRIPTION	DESCRIPTION	BESCHREIBUNG	BESCHRIJVING	DESCRIPCIÓN
20	20198813	20190068	● Pannello laterale	Panneau latéral	Lateral panel	Seitenpaneel	Zijpaneel	Panel lateral
30	20198814		● Flangia fumi	Bride fumée	Flue gas flange	Rauchgasflansch	Rookflens	Brida humos
40	4366888		● Tappo	Bouchon	Plug	Verschluss	Dop	Tapón
60	20198854		● Guarnizione	Joint	Seal	Dichtung	Afdichting	Junta
255	4R102333		● Deflettore aria	Défecteur d'air	Air deflector	Luftableiter	Deflector lucht	Deflector de aire

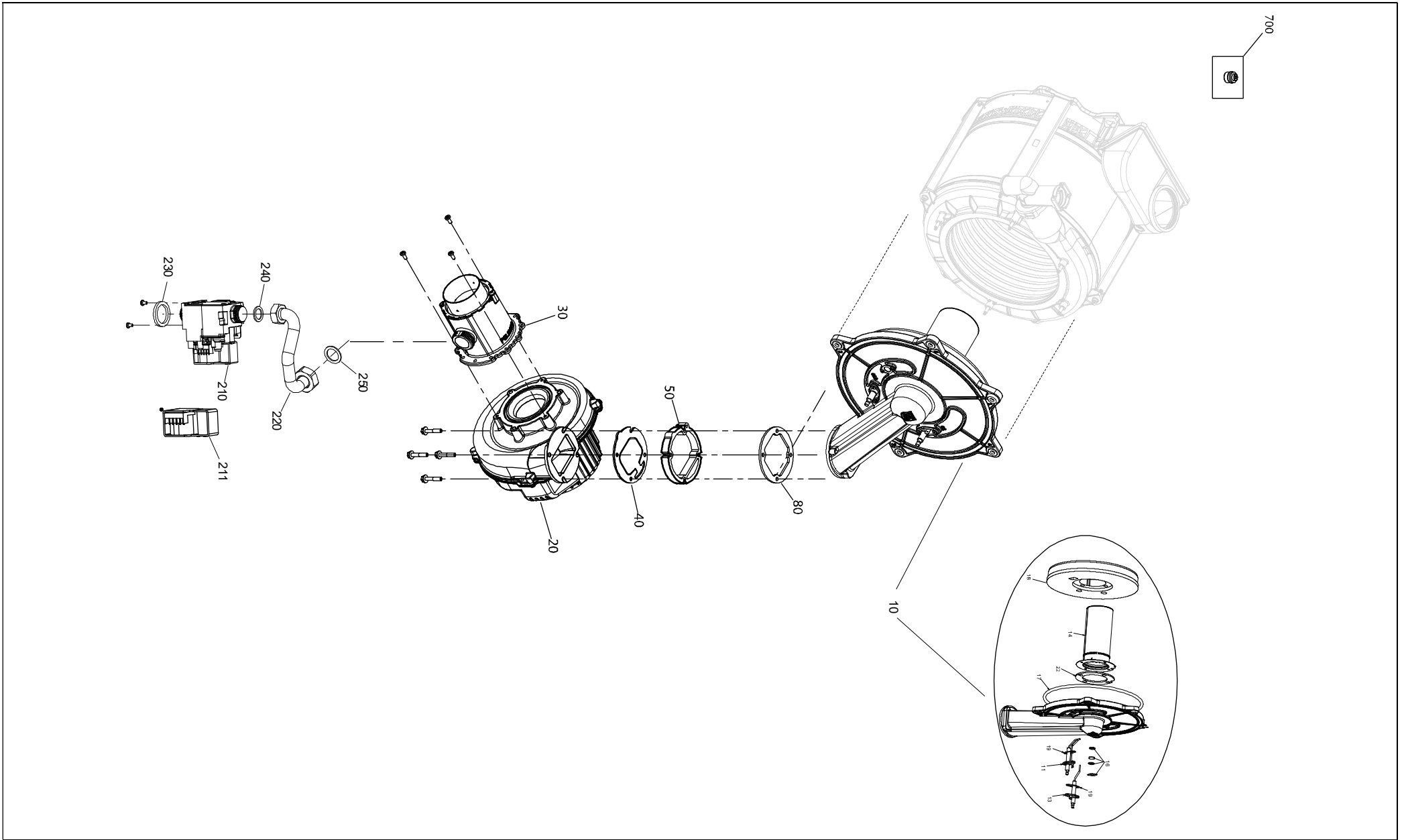

N.	COD.	RC 20190068	DESCRIZIONE	DESCRIPTION	DESCRIPTION	BESCHREIBUNG	BESCHRIJVING	DESCRIPCIÓN
10	20198826	•	Convogliatore	Convoyeur d'air	Suction duct	Luftleitblech	Transportinrichting	Transportador
11	20198765	•	Elettrodo accensione	Électrode d'allumage	Ignition electrode	Zündelektrode	Ontstekingelektrode	Electrodo de encendido
13	20198767	•	Elettrodo rilevazione	Électrode de détection	Flame detection electrode	Prüfelektrode	Meetelektrode	Electrodo de revelación
14	20198829	•	Brucciatore	Brûleur	Burner	Brenner	Brander	Quemador
16	20198769	•	Vetrino	Regard	Viewing port	Verschlußstopfen	Glaasje	Cubreobjeto
17	20198830	•	Guarnizione	Joint	Seal	Dichtung	Afdichting	Junta
18	20198827	•	Isolante	Protection échangeur	Insulating	Isolierung	Isolatie	Aislamiento
19	20198768	•	Guarnizione	Joint	Seal	Dichtung	Afdichting	Junta
20	20198831	•	Ventilatore	Ventilateur	Fan	Gebälse	Ventilator	Ventilador
22	20198828	•	Guarnizione	Joint	Seal	Dichtung	Afdichting	Junta
30	20198832	•	Mixer	Mixer	Mixer	Mixer	Mixer	Mezclador
40	20198819	•	Valvola clapet	Clapet	Flap valve	Clapetventil	Stuw	Válvula de retención
50	20198820	•	Distanziale	Entretoise	Spacer	Distanzstück	Compleet tussenstuk verdeler	Distanciador (separador)
80	4R105483	•	Guarnizione	Joint	Seal	Dichtung	Afdichting	Junta
210	4R000835	•	Valvola gas	Vanne gaz	Gas valve	Gasventil	Gasklep	Válvula de gas
211	4R000824	•	Bobina	Bobine	Coil	Spule	Spoel	Bobina
220	20198815	•	Rampa	Tuyau	Pipe	Strecke	Buisje	Rampa
230	4R105534	•	Guarnizione flangia	Joint bride	Flange seal	Flanschdichtung	Flensafdichting	Junta brida
240	4363389	•	Guarnizione	Joint	Seal	Dichtung	Afdichting	Junta
250	4363781	•	Guarnizione	Joint	Seal	Dichtung	Afdichting	Junta
700	20200244	•	Kit trasformazione	Set de conversion	Conversion kit	Set-Umrüstung	Ombouwset	Kit transformación

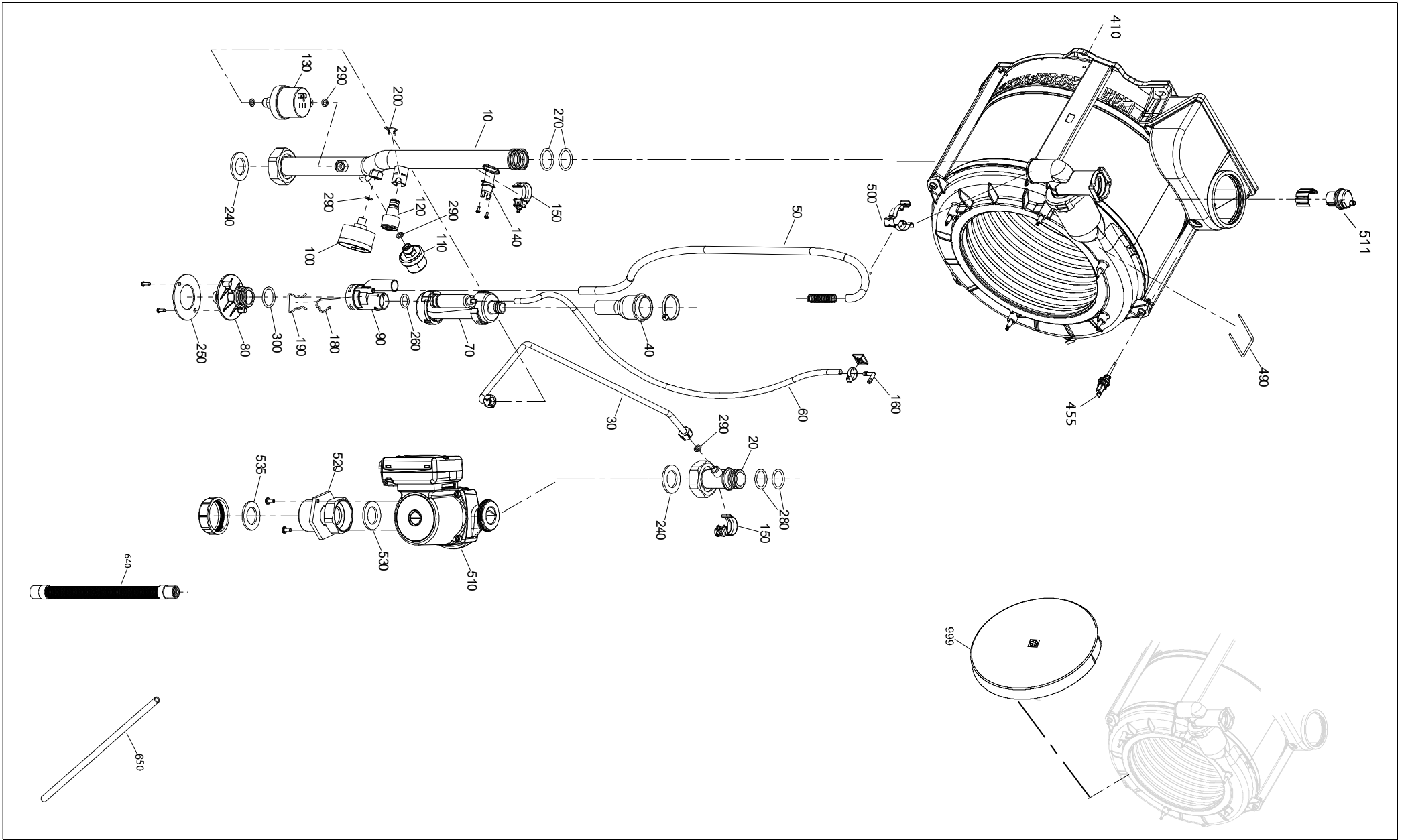

N.	COD.	RC	DESCRIZIONE	DESCRIPTION	DESCRIPTION	BESCHREIBUNG	BESCHRIJVING	DESCRIPCIÓN
10	20198809		● Rampa	Tuyau	Pipe	Strecke	Buisje	Rampa
20	20198812		● Rampa	Tuyau	Pipe	Strecke	Buisje	Rampa
30	20198808		● Rampa	Tuyau	Pipe	Strecke	Buisje	Rampa
40	20198807		● Tubo scarico condensa	Tuyau évacuation buée	Condensation drainage pipe	Abflussrohr Kondenswasser	Condensafvoerslang	Tubo evacuación de condensados
50	4R105723		● Kit sfiato manuale	Kit évent manuel	Manual venting kit	Handentlüfter-set	Handleiding ontluchting kit	Kit respiradero manual
60	4R108689		● Tubetto silicone	Tube en silicone	Silicon tube	Silikonröhrchen	Silicone slang	Tubo de silicona
70	4R109674		● Sifone	Siphon	Syphon	Syphon	Sifon	Sifón
80	20195198		● Supporto	Support	Support	Halter	Selhouder	Cierre
90	20198804		● Collettore scarico condensa	Collecteur évacuation condensation	Condensation drainage manifold	Auspuffsammler	Colector de drenagem	Colector evacuación de condensados
100	4R105331		● Manometro	Manometre	Pressure gauge	Manometer	Manometer	Manómetro
110	20198544		● Trasduttore di pressione	Transducteur de pression	Pressure transducer	Druckgebersatz	Druktransductor	Kit trasductor presión
120	4366392		● Rubinetto scarico	Robinet de vidange	Drain cock	Ablasshahn	Afvoerkraan	Llave de vaciado
130	20198856		● Pressostato	Pressostat	Pressure switch	Druckwächter	Drukregelaar	Presostato
140	4364948	C	● Termostato limite	Thermostat limite	Maximum temperature thermostat	Grenzthermostat	Klicson	Termostato límite
150	20198818		● Sonda temperatura	Sonde température	Temperature probe	Temperaturfühler	Temperatuur sensor	Sensor temperatura
160	4R100551		● Raccordo	Raccord	Connector	Anschluss	Aansluiting	Racor
180	4364962		● Molletta	Clip	Clip	Feder	Clip	Linguete
190	4365407		● Molletta	Clip	Clip	Feder	Clip	Linguete
200	4366394		● Molletta	Clip	Clip	Feder	Clip	Linguete
240	20198543		● Guarnizione	Joint	Seal	Dichtung	Afdichting	Junta
250	4R109676		● Guarnizione	Joint	Seal	Dichtung	Afdichting	Junta
260	4R105704		● Anello OR	Joint d'étancheite	O-ring	OR-Dichtung	Pakkingring	Anillo de cierre
270	20198803		● Guarnizione	Joint	Seal	Dichtung	Afdichting	Junta
280	20198817		● Guarnizione	Joint	Seal	Dichtung	Afdichting	Junta
290	4363799		● Guarnizione	Joint	Seal	Dichtung	Afdichting	Junta

N.	COD.	RC 20190068	DESCRIZIONE	DESCRIPTION	DESCRIPTION	BESCHREIBUNG	BESCHRIJVING	DESCRIPCIÓN
300	4365860	•	Anello di tenuta	Joint d'etancheite	O-ring	OR-Dichtung	Pakkingring	Anillo de cierre
410	20198824	•	Scambiatore condensante	Echangeur condensant	Heat exchanger	Kondens austauscher	Condensatie wisselaar	Intercambiador condensador
455	4R105463	•	Sonda fumi	Sonde fumée	Flue gas probe	Abgasfühler	Rook sensor	Sonda de humos
490	4366963	•	Molletta	Clip	Clip	Feder	Clip	Linguete
500	20198810	•	Molletta	Clip	Clip	Feder	Clip	Linguete
510	20198811	•	Circolatore	Circulateur	Circulator	Umlaufpumpe	Circulatiepomp	Circulador
511	4365707	•	Disaeratore	Purgeur automatique	Deaerator	Entlüfter	Ontluchter	Purgador
520	20198806	•	Rampa	Tuyau	Pipe	Strecke	Buisje	Rampa
530	20198543	•	Guarnizione	Joint	Seal	Dichtung	Afdichting	Junta
535	20198543	•	Guarnizione	Joint	Seal	Dichtung	Afdichting	Junta
640	4R102771	•	Tubo scarico condensa	Tuyau évacuation buée	Condensation drainage pipe	Abflussrohr Kondenswasser	Condensafvoerslang	Tubo evacuación de condensados
650	4R108015	•	Kit tubetti anticondensa	Kit tuyau antibuée	Anticondensation tube kit	Kondenswasserschutzrohr e	Kit buisjes	Kit tubos anticondensación
999	20198825	•	Pannello isolamento	Panneau isolation	Insulation panel	Isolier tafel	Paneelvulling	Panel aislante

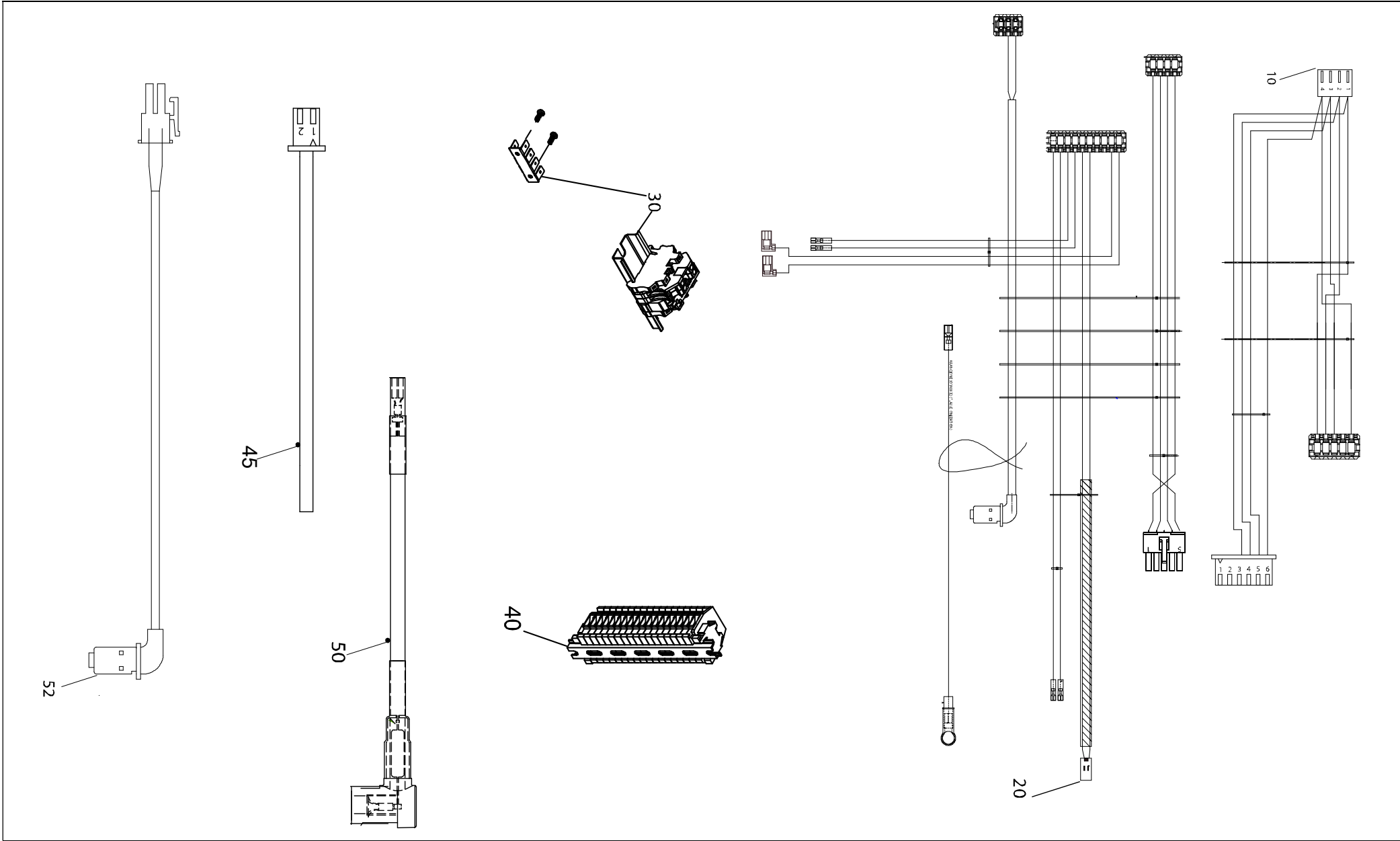

N.	COD.	RC	DESCRIZIONE	DESCRIPTION	DESCRIPTION	BESCHREIBUNG	BESCHRIJVING	DESCRIPCIÓN
10	20198823	20190068	• Cablaggio	Câblage	Wiring	Verkabelung	Bekabeling	Cableado
20	20198822		• Cablaggio bassa tensione	Câblage à basse tension	Low tension wiring	Verkabelung Niederspannung	Bekabeling laagspanning	Cableado baja tensión
30	20198821		• Cablaggio alimentazione	Câblage alimentation	Feed wiring	Speiseverkabelung	Bekabeling voeding	cableado alimentación
40	20198565		• Cablaggio	Câblage	Wiring	Verkabelung	Bekabeling	Cableado
45	4R109867		• Cablaggio termostato	Cablage thermostat	Thermostat wiring	Thermostat Verkabelung	Bekabeling thermostaat	Cableado termostato
50	4R109814		• Cablaggio candela	Câblage bougie	Spark wiring	Kerze Verkabelung	Bekabeling bougie	Cableado electrodo
52	20198833		• Cablaggio pompa	Cablage circulateur	Pump wiring	Pumpe Verkabelung	Pomp bekabeling	Cableado circulador

A = Ricambi per dotazione minima - Pièces détachées pour équipement minimum - Spare parts for minimum fittings - Ersatzteile für minimale Ausstattung - Reserveonderdelen voor minimale uitrusting - Recambios para equipamiento mínimo

A+B = Ricambi per dotazione base di sicurezza - Pièces détachées pour équipement standard de sécurité - Spare parts for basic safety fittings - Ersatzteile für sicherheitsgrundausrüstung - Reserveonderdelen voor basis veiligheidsuitrusting - Recambios para equipamiento básico de seguridad

A+B+C = Ricambi per dotazione estesa di sicurezza - Pièces détachées pour équipement complet de sécurité - Spare parts for extended safety fittings - Ersatzteile für erweiterte Sicherheitsgrundausrüstung - Reserveonderdelen voor uitgebreide veiligheidsuitrusting - Recambios para equipamiento general de seguridad



Riello S.p.A.
37045 Z.A.I. di San Pietro di Legnago (Verona) Via Ing. Pilade Riello, 7
Tel. 0442/630.111 - Fax 0442/22378 <http://www.riello.it>
archivio <http://ics.riello.it>

La nostra azienda, nella costante azione migliorativa sul prodotto, si riserva la possibilità di modificare i dati riportati in questo documento in qualsiasi momento e senza preavviso. - Puisque l'entreprise cherche constamment à perfectionner toute sa production, les caractéristiques esthétiques et dimensionnelles, les données techniques, les équipements et les accessoires, peuvent subir des modifications. - The manufacturer strives to continuously improve all products. Appearance, dimensions, technical specifications, standard equipment and accessories are therefore liable to modification without notice. - Da das Unternehmen konstant um die Perfektionierung seiner Produktion bemüht ist, können das äußere Erscheinungsbild, die Abmessungen, die technischen Daten, die Ausstattungen sowie Zubehörteile Änderungen unterworfen werden. - In een voortdurend streven naar het verbeteren van onze producten, behouden wij ons het recht voor om de gegevens in dit document op elk moment te wijzigen, zonder kennisgeving vooraf. - Nuestra empresa dedica sus esfuerzos al constante perfeccionamiento de toda su producción; por eso las características estéticas y las dimensiones, los datos técnicos, los equipamientos y los accesorios pueden estar sometidos a variación.